

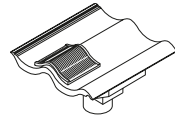

# Here to help

## Components

For mechanical extract and soil vent pipe installation use flexible pipe (code 39091).



Anglia Contour  
Vent Terminal  
(double tile unit)  
(code 460)

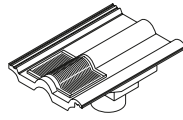

Double Roman  
Contour Vent  
Terminal  
(code 453)

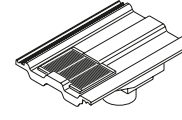

Ludlow Major  
Contour Vent  
Terminal  
(code 456)

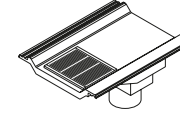

Wessex Contour  
Vent Terminal  
(code 459)

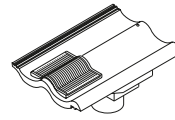

Mendip Contour  
Vent Terminal  
(code 452)

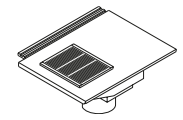

Edgemere Contour  
Vent Terminal  
(code 465)

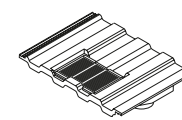

Ludlow Plus Contour  
Vent Terminal  
(double tile unit)  
(code 457)

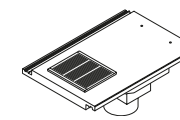

Modern Contour  
Vent Terminal  
(code 451)

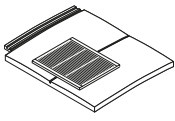

Ashmore Contour  
Vent Terminal  
(code 450)

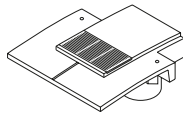

Universal Plain  
Tile Vent Terminal  
(double tile unit)  
(code 455)

## CONTOUR TILE VENT TERMINALS

Offering an unequalled combination of performance and appearance, contour vent terminals are designed to provide ventilation of the roof space, either at high or low level for either mechanical extraction or soil vent pipes whilst retaining an uninterrupted roofscape.



## Tell me more

Call 08705 626400  
Email [info@marley.co.uk](mailto:info@marley.co.uk)  
Or visit [marley.co.uk](http://marley.co.uk)

Marley, Lichfield Road, Branston,  
Burton upon Trent, DE14 3HD

December 2018

FIXING INSTRUCTIONS

# Contour Tile Vent Terminals

INCORPORATING  
UNIVERSAL PLAIN TILE  
VENT TERMINAL



Marley

## Installation for Ashmore, Ludlow Plus, Plain Tile and Anglia

- 1 Felt and batten roof in normal manner.

Note: If unit is to be used as a roof void vent, circular spigot and 5mm of box section must be sawn off on site to achieve maximum designed free vent area.

- 2 Determine position of vent tile (ideally mid-span between rafters) and remove section(s) of tiling batten to accommodate unit.

Note: the battens should be cut to provide a gap of 210mm when fitting with clay plain tiles and 260mm with concrete plain tiles.

- 3 Form a 'V' cut in underlay in manner shown to accommodate rectangular spigot.
- 4 Make a horizontal cut in underlay, 390mm long, at a distance 150mm above bottom edge of tiling batten above unit and slide soaker tray under batten and through slit in underlay (Fig. 1).
- 5 Secure soaker tray by folding cut underlay over batten and nail into bottom edge of tiling batten above (Fig. 2).
- 6 Insert tile unit and mechanically fix using screws provided (Fig. 3).
- 7 Continue tiling in normal manner.

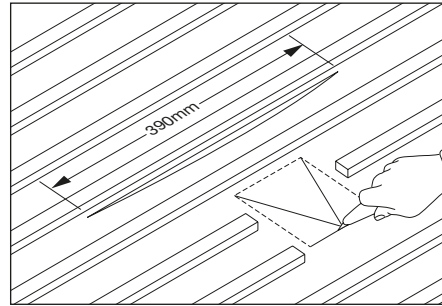

Fig. 1 – Make aperture in underlay

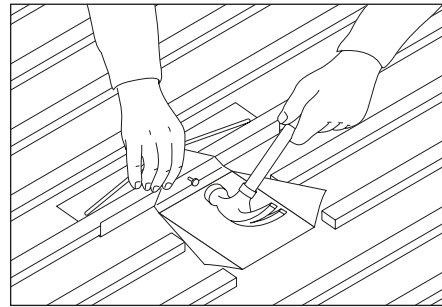

Fig. 2 – Secure soaker tray

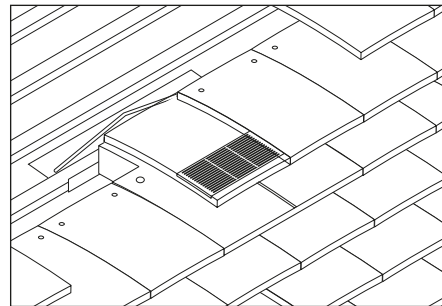

Fig. 3 – Fix contour tile vent

## Installation for Ludlow Major, Edgemere, Mendip, Modern, Double Roman, Duo Modern, Wessex

- 1 Felt and batten the roof in normal manner.

Note: If unit is to be used as a roof void vent, circular spigot and 5mm of box section must be sawn off on site to achieve designed free vent area.

- 2 Determine position of tile vent terminal (ideally mid-span between rafters) and form a 'V' cut in the underlay to accommodate box spigot (Fig. 4).
- 3 Make horizontal cut in underlay, 390mm long, at a distance 150mm above bottom edge of tiling batten, supporting vent tile and slide soaker tray under batten and through slit in underlay (Fig. 5).
- 4 Secure soaker tray by folding cut underlay over the batten and nail into the top edge of the tiling batten above.
- 5 Insert tile vent unit within main body of tiling and mechanically fix using standard tile clip fixings (Fig. 6).

Note: This product is not suitable as an exhaust for hot gases.

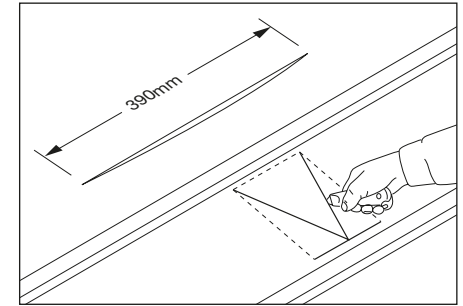

Fig. 4 – Make aperture in underlay

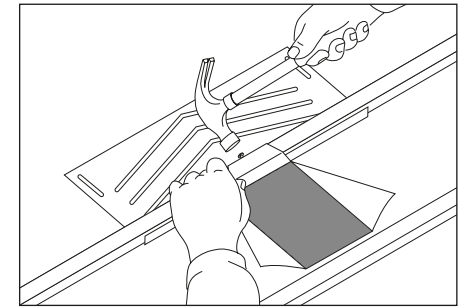

Fig. 5 – Secure soaker tray

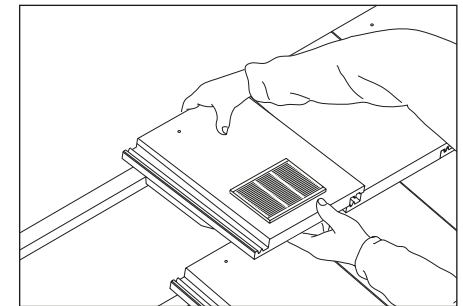

Fig. 6 – Fix contour tile vent