

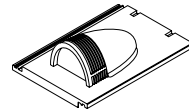

Here to help

Components

For mechanical extract and soil vent pipe installation use flexible pipe (code 39091).



Modern Vent Terminal (code 295)

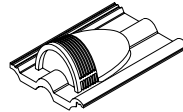

Double Roman Vent Terminal (code 298)

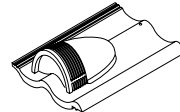

Mendip Vent Terminal (code 294)

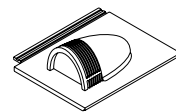

Edgemere Vent Terminal (code 259)

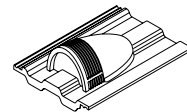

Ludlow Major Vent Terminal (code 297)

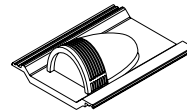

Wessex Vent Terminal (code 296)

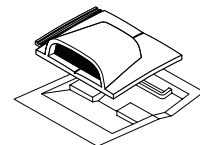

Ashmore Ventilation Roof Tile (with catchment tray) (code 263)

Pressure Resistance (Pa)

Tile	Free area (mm ²)	Pa (litres/sec airflow)		
		15	30	60
Ashmore	4500	-	-	-
Double Roman	7614	6.5	24.8	89.1
Ludlow Major	7665	6.7	24.3	88.4
Mendip	7107	7.6	27.9	101.7
Modern	7081	7.6	28.6	106.7
Wessex	6929	7.9	29.7	110.6
Edgemere	7081	7.6	28.6	106.7

TILE VENT TERMINALS

Tile vent terminals can be used for high or low level ventilation and are also designed for connection to mechanical extract ventilation systems and soil vent pipes.



Tell me more

Call 08705 626400
Email info@marley.co.uk
Or visit marley.co.uk

Marley, Lichfield Road, Branston,
Burton upon Trent, DE14 3HD

December 2018

FIXING INSTRUCTIONS

Tile Vent Terminals

INCLUDING ASHMORE VENTILATION ROOF TILE



Installation

- 1 Locate vent tile clear of rafters and place special polystyrene end spacer marked 'Template' flat onto underlay at desired position (Fig. 1).
- 2 Mark batten with corresponding arrows on template to assist setting out.
- 3 Remove lower course of tiles and replace template flat onto underlay and mark outline of hole.
- 4 Carefully cut out a cross with a sharp knife.
- 5 Make a horizontal cut in the underlay, 390mm long, at a distance 150mm above bottom edge of tiling batten supporting vent tile.
- 6 Slide soaker tray under batten and through slit in underlay.
- 7 Secure soaker tray by folding cut underlay over batten and nail into top edge of tiling batten above (Fig. 2).
- 8 Lay vent terminal ensuring that pipe enters hole cleanly and is fixed in accordance with required fixing specification.
- 9 Lay adjacent tiling in normal manner (Fig. 3).

Note: Tile vent terminals may be used for termination of mechanical extract systems or soil vent pipes, but must be connected by a plumber. To avoid misalignment problems, connections to 110mm pipework should be carried out using a flexible pipe connector (Code 39091) and any long runs of pipework should be supported to avoid strain on the terminal.

To enable the completed pipework to be tested, the vent grille may be prised out of the concrete hood, to allow an inflatable bag to be used, and replaced later when testing is completed. Where the terminals are used for extraction of soil vent pipes they must not terminate lower than 900mm above any opening into a building within 3m.

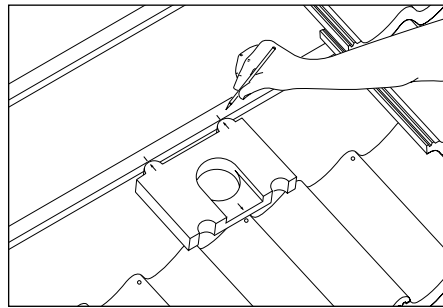

Fig. 1 - Mark position

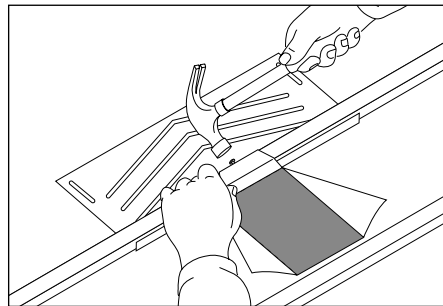

Fig. 2 - Cut and nail back underlay

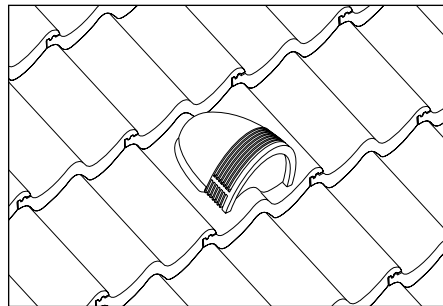

Fig. 3 - Continue tiling

Ashmore ventilation roof tile

The Ashmore ventilation roof tile is designed to provide ventilation of the roof space, either at high or low level and have a colour-matched concrete hood with matt black aluminium grille. Incorporating a standard tile base, the terminal is simply substituted for a standard tile and fixed accordingly. Free area: 3,000mm²/m.

- 1 Select a position for vent tile clear of rafters and lay catchment tray in position. Cut a 170mm gap in the batten to accommodate the catchment tray.
- 2 Mark airway aperture on underlay (Fig. 4).
- 3 Remove catchment tray and cut underlay back to tiling batten to form a flap which should be pulled up so there is a gap of approx. 6mm between underside of batten and underlay.
- 4 Nail flap to top of tiling batten (Fig. 5).
- 5 Lay ventilation tile over catchment tray and clip or nail, if necessary (Fig. 6).
- 6 Lay adjacent tiling in normal manner (Fig. 7).

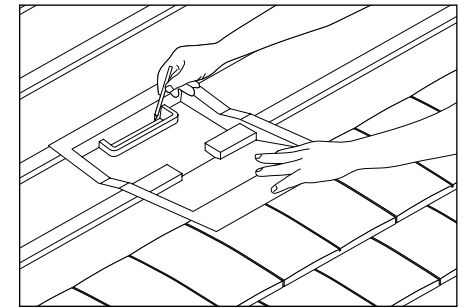

Fig. 4 - Mark aperture

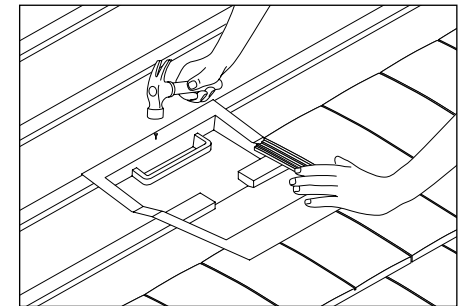

Fig. 6 - Nail catchment tray

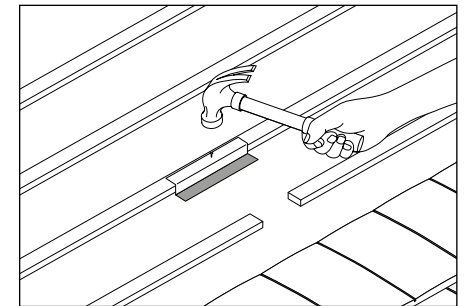

Fig. 5 - Cut and nail back underlay

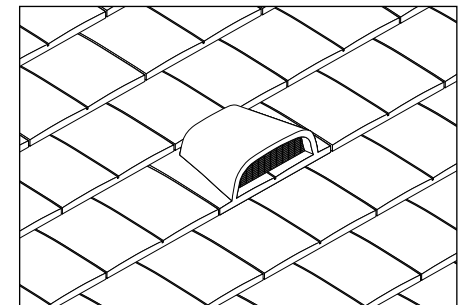

Fig. 7 - Continue tiling